

# SIZE380 PULL, TUBULAR SOLENOID

UNIT :  $\frac{\text{mm}}{\text{inch}}$   
SHOWN ENERGIZED

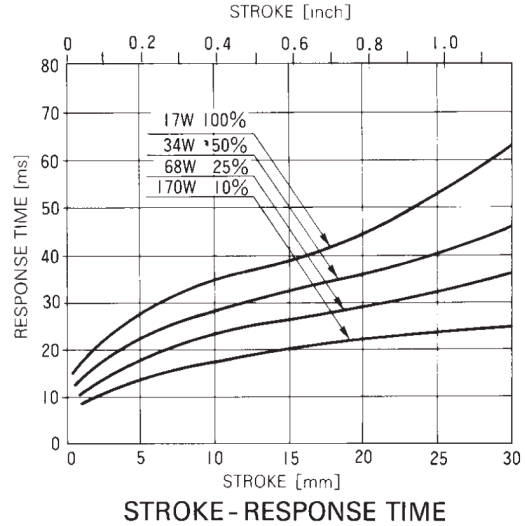

WEIGHT : 497g  
PLUNGER : 95g

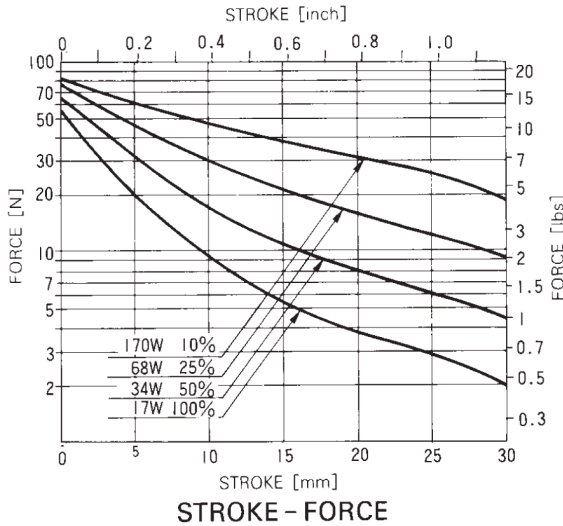
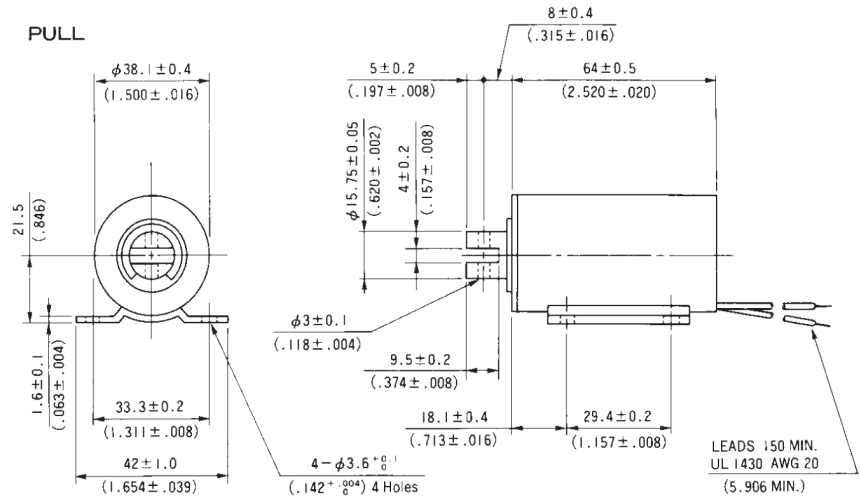

## COIL DATA

Heat sink : 150×150×3 mm aluminum

duty cycle = $\frac{\text{"on" time}}{\text{"on" time} + \text{"off" time}} \times 100\%$			100% continuous	50% or less	25% or less	10% or less
MAX. "on" time in seconds			∞	420	100	25
watts at 20°C			17	34	68	170
ampere-turns at 20°C			1800	2546	3600	5692
AWG no.	resistance $\Omega \pm 10\%$ (at 20°C)	no. turns	volts DC			
19	0.93	432	3.9	5.5	7.8	12.4
20	1.34	488	4.9	6.9	9.8	15.5
21	2.34	680	6.2	8.7	12.3	19.5
22	3.35	770	7.8	11.1	15.7	25
23	5.58	1030	9.8	13.9	19.7	31
24	9.30	1344	12.4	17.6	25	39
25	14.9	1712	15.7	22	31	50
26	24.0	2180	19.9	28	40	63
27	36.9	2680	25	35	50	79
28	58.4	3322	32	45	63	100
29	87.5	4008	39	56	79	124
30	148	5292	50	71	101	159
31	224	6360	63	90	127	200
32	344	7956	78	110	155	246
33	554	10070	100	141	199	315
34	871	12400	127	179	253	401
35	1360	15300	160	227	320	507
36	2140	19200	201	284	402	636

(주)신우솔텍 TEL : 02-584-5995