

SIZE133 PULL, 133 PUSH TUBULAR SOLENOIDS

UNIT : $\frac{mm}{(inch)}$
SHOWN ENERGIZED

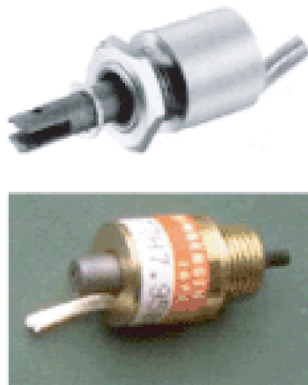

WEIGHT : 15g
PLUNGER
PULL : 4g
PUSH : 2g

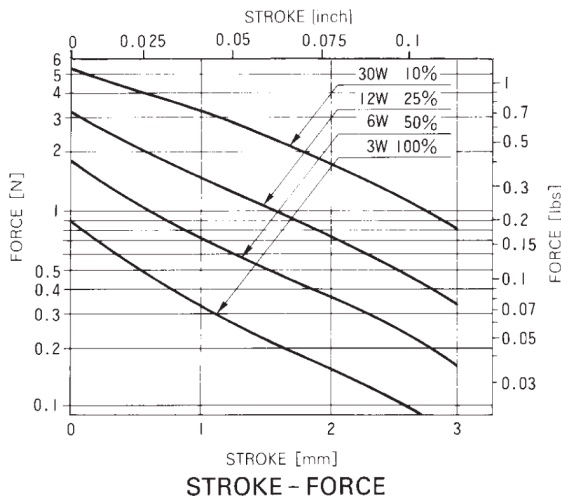
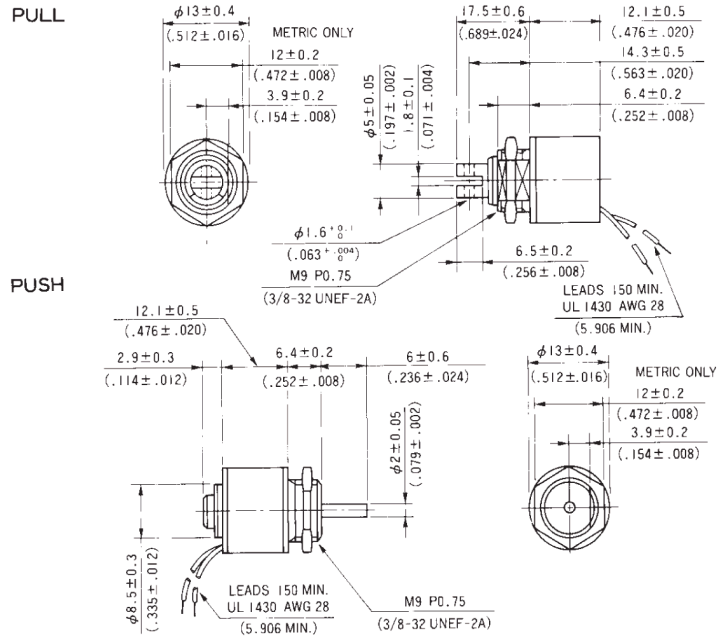

STROKE - FORCE

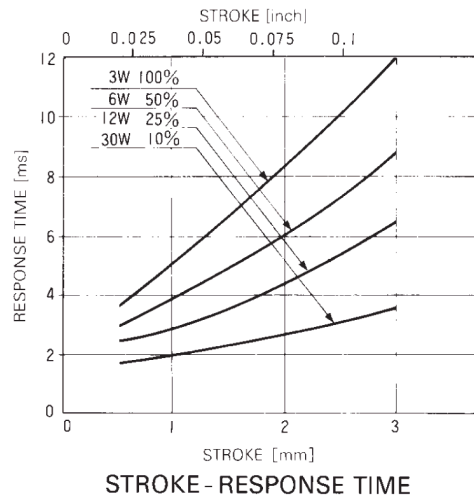

STROKE - RESPONSE TIME

COIL DATA

Heat sink : 50×50×3mm aluminum

duty cycle = $\frac{\text{"on" time}}{\text{"on" time} + \text{"off" time}} \times 100\%$			100% continuous	50% or less	25% or less	10% or less
MAX. "on" time in seconds			∞	38	4	1
watts at 20°C			3	6	12	30
ampere-turns at 20°C			232	330	465	735
AWG no.	resistance $\Omega \pm 10\%$ (at 20°C)	no. turns	volts DC			
29	1.03	141	1.7	2.4	3.4	5
30	1.6	175	2	3	4.3	7
31	2.5	217	2.7	3.8	5.4	9
32	3.9	268	3.4	4.8	7	11
33	6.1	332	4.3	6	9	14
34	9.5	410	5.4	7.7	11	17
35	14.8	506	6.8	10	14	22
36	23.0	625	8.5	12	17	27
37	35.8	770	10.8	15	22	34
38	55.7	949	13.6	19	27	43
39	86.5	1169	17	24	34	54
40	134	1440	21.6	31	43	68
41	209	1774	27	39	55	87
42	324	2184	34.5	49	69	109
43	503	2688	43.5	62	87	137