

SIZE874 ROTARY SOLENOID

UNIT : $\frac{\text{mm}}{\text{inch}}$
 SHOWN DE-ENERGIZED, RIGHT HAND ROTATION

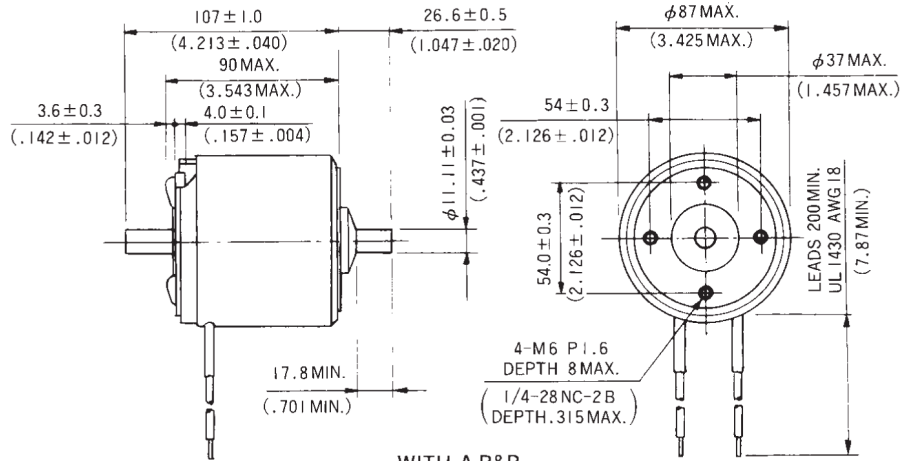

WEIGHT (ABD&R) : 3,056g



WITH A,B&R

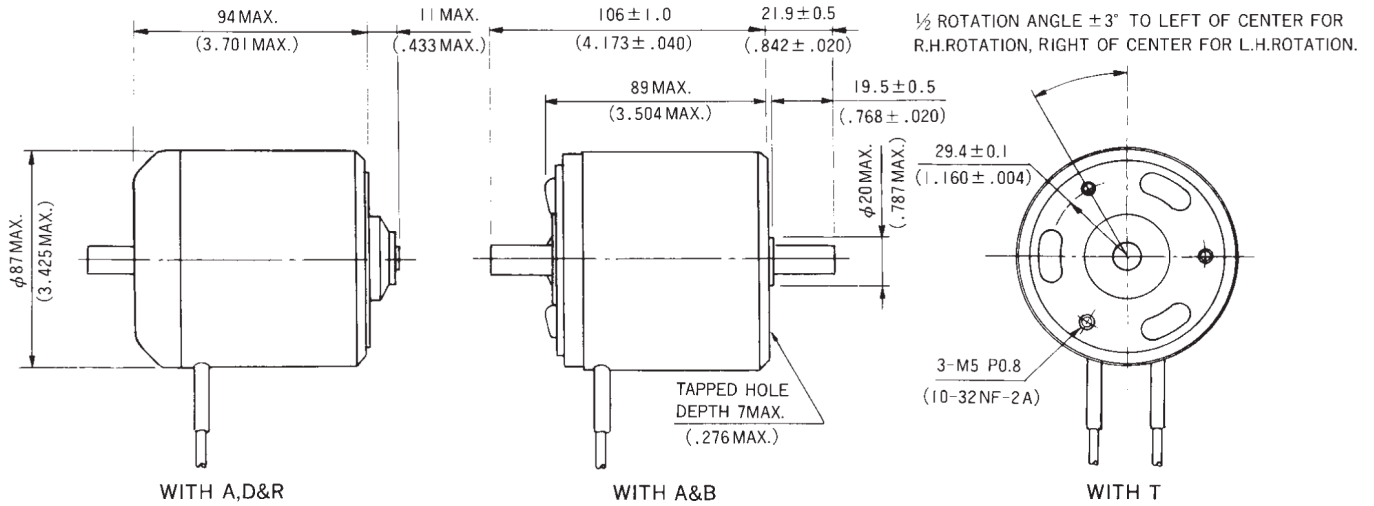

WITH A,D&R

WITH A&B

WITH T

COIL DATA

Heat sink : 520×520×3mm aluminum

Return spring torque : 0.09~0.14 N·m

duty cycle = $\frac{\text{"on" time}}{\text{"on" time} + \text{"off" time}} \times 100\%$		100% continuous	75% or less	50% or less	25% or less	10% or less	
MAX. "on" time in seconds		∞	85	72	43	20	
watts at 20°C		41	54.5	82	164	410	
ampere-turns at 20°C		2590	2990	3663	5180	8190	
gross starting torque at 20°C (N·m)		25°	3.6	4.7	6.5	10	13
		35°	2.4	3.1	4.2	6.4	8.7
		45°	2.0	2.6	3.6	5.5	7.4
		67.5°	1.0	1.3	1.8	2.9	3.9
		95°	0.66	0.82	1.1	1.7	2.2
AWG no.	resistance $\Omega \pm 10\%$ (at 20°C)	no. turns	volts DC				
18	2.54	630	10	12	15	21	33
19	4.15	828	13	15	18	26	41
20	6.38	1047	16	18	22	32	50
21	11.14	1408	20	24	29	41	65
22	16.8	1723	25	29	36	51	80
23	25.8	2046	33	38	46	65	103
24	42.5	2711	41	47	57	81	128
25	66.3	3279	52	60	74	105	166
26	105	4151	66	76	93	131	207
27	165	5190	82	95	116	165	260
28	261	6500	104	120	147	208	329
29	422	8340	131	151	185	262	—
30	664	10230	168	194	238	336	—
31	968	12410	202	233	286	—	—
32	1520	15200	259	299	366	—	—

(주)신우솔텍 TEL : 02-584-5995